

A (1:1)

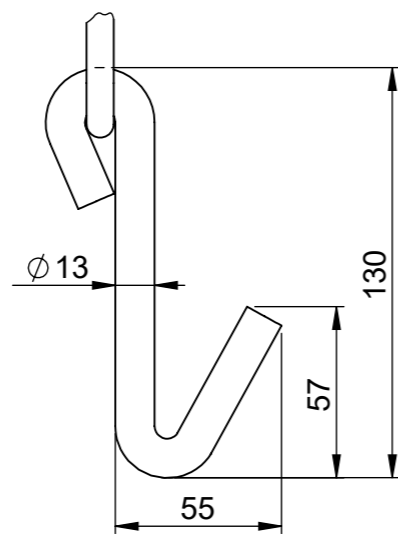

B (2 : 5)

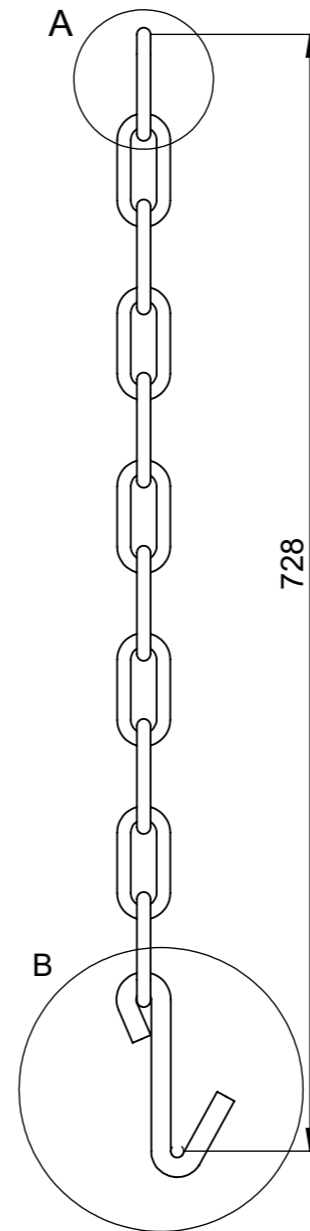

<b>Specifications:</b>	<b>Loads:</b>	Shear	Tension	2						
Material: Q235B	Breaking load BL		150 kN	1	New drawing	24/11/2020	MDH	BVQ	AC	
Finish: Paint - RAL 5017	Proof load PL		112 kN	Rev.	Description of issue	Date	Drawn by	Checked by	Approved by	
Chain: 11 links	Safe working load SWL		75 kN	<b>Product ref.: TA-3</b>					<b>Status: APPROVED</b>	
Total weight: 0.82 kg				<b>Title: TAILCHAIN FOR 11mm LEVER LT-815-N</b>					Scale: 1:5 Format: A3	
Ownership of International Lashing Systems n.v. Duplication or disclosure to third parties in any form whatsoever, is prohibited without written permission of the owner.		 <b>ILS</b> <b>International Lashing Systems</b> How secure is your cargo?		Phone: +32-3-234.28.80 Website: www.ils.be E-mail: info@ils.be						